

液压原理图

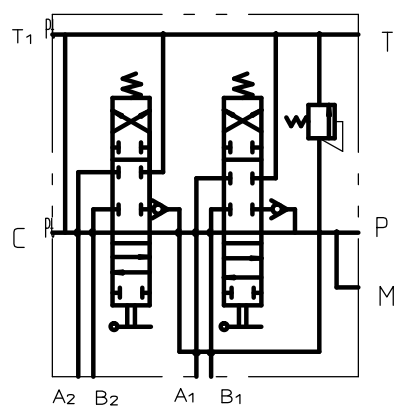

Technical requirements:

1. Rated flow rate:80L/min
2. Maximum working pressure:25MPa;
3. Safety valve setting pressure:20MPa;
4. Each moving part must be flexible and free from any sticking or jamming;
5. Oil port size:P/A/B:G1/2 T/C:G3/4 ; Invert the orifice at an angle of 1x45 °;
6. Each inlet and outlet should be sealed with plastic oil plugs to prevent dust;
7. The form, length, and color of the handle cover are determined according to user requirements.

				设计			图样标记			2P80-OT
				制图			重量	比例		
				描图						HYDRAULIC VALVE
				校对			共张	第张		
				工艺检查						
				标准化检查						
标记	更改内容或依据	更改人	日期	审核						